



Manhole Products

60" Type 3 Precast Manhole WSDOT
B-15.60-02

Grade Adjustment Rings Available

- 2", 3", 4", 6"

Hole or Knock Out Dimensions

- Maximum hole size is 48 inches
- 8 inches of minimum distance between holes
- 2 inch diameter lifting holes provided
- Cored, cast-in and custom block-out/knock-outs available

Conformity Standards

- ASTM C478 manhole
- ASTM C443 rubber gasket joint
- ASTM D4104 polypropylene steps and ladders
- Washington State APWA / WSDOT Standard

Options Available

- Pre-channeled base
- Specialized coatings
- Custom hatches
- Predl systems monolithic GU lined base
- Kor-N-Seal boots
- 1' thru 10' Polypropylene ladders

Section Specifications

Height	Section	Base
12"	1,240 LBS	2,240 LBS
24"	2,507 LBS	3,507 LBS
36"	3,773 LBS	4,773 LBS
48"	5,040 LBS	6,040 LBS
60"	6,306 LBS	7,306 LBS
72"	7,573 LBS	8,573 LBS

Base Slab	Flat Top
2,622 LBS	2,663 LBS

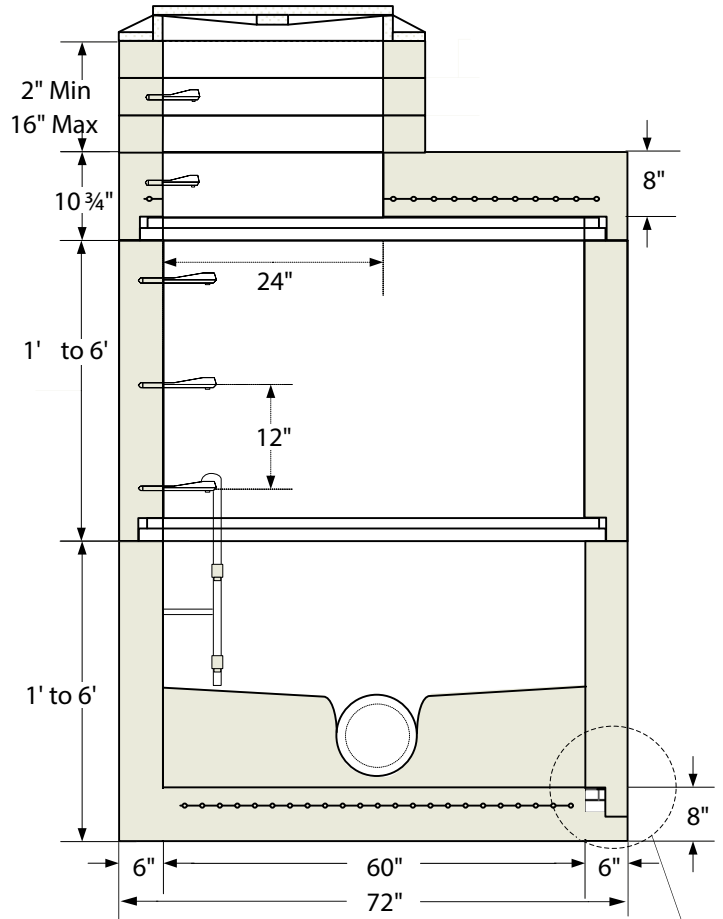

Top Slab Plan View

Gasket Shown Uncompressed

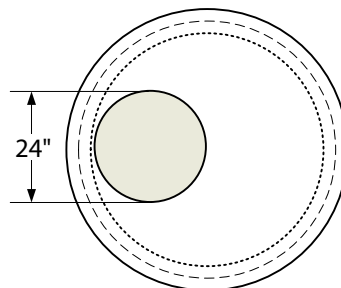

1PC GASKET PROFILE

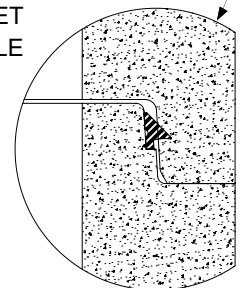

Note: Drawings not to scale

www.shopeconcrete.com

1-800-422-7560 [TOLL FREE]



Shope Concrete, LLC
1618 East Main Avenue
Puyallup, WA 98372-3142

(253) 848-1551
Fax Line 1 (253) 845-0292
Fax Line 2 (253) 864-6172

